



D

**Drosselablaufschacht  
begehbar / PKW-befahrbar**

Artikel-Nr.  
article no.

340028/ 340029

Choke drain shaft suitable for  
pedestrian/ vehicle loading

Pozos de estrangulación  
por peatrones/ por coches

Regard Débit Régulé  
piétons / véhicules

GB

ES

FR

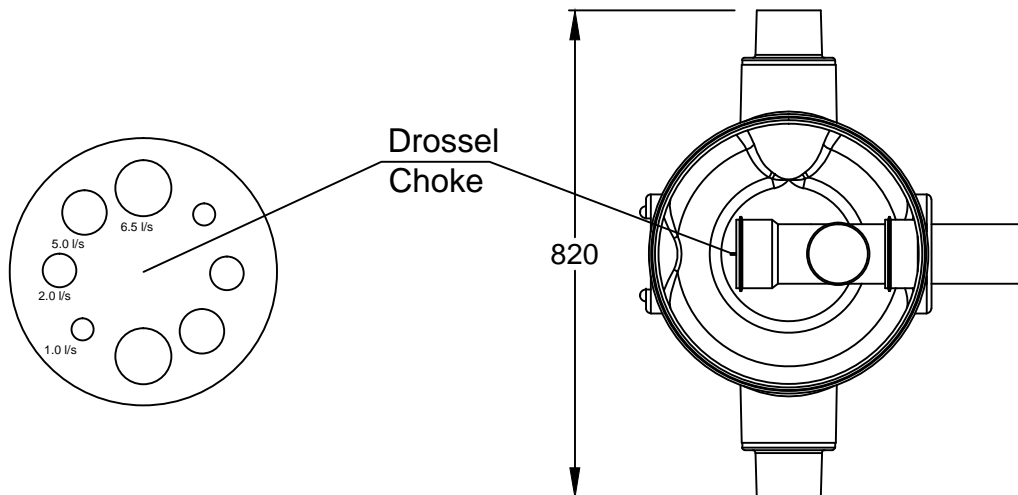
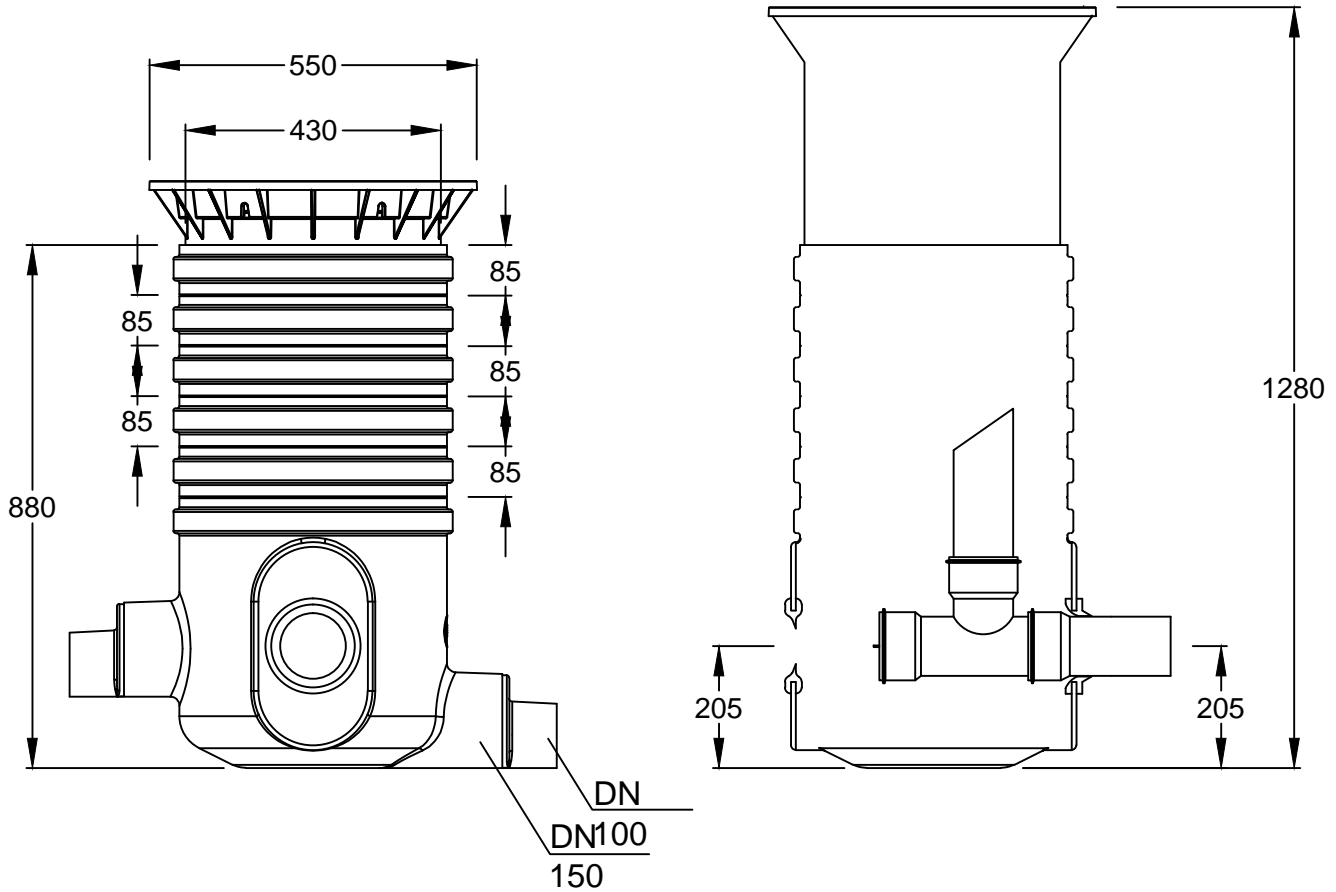

**Otto Graf GmbH**  
Carl-Zeiss-Str. 2-6  
DE-79331 Teningen  
Germany  
info@graf.info  
www.graf.info

**Zeichnungsinformation  
drawing information**

gezeichnet  
drawn NDO  
Datum  
date 24.03.2014  
Toleranz  
tolerance +/- 3 %

**Artikelinformation  
article information**

Gewicht  
weight ca. 13 / 42 kg

Alle Maßangaben in mm  
all dimension in mm